

PVD3D2N

Proportional Valve Driver

Two PWM solenoid outputs, in sealed plastic enclosure



PWM

CONTROLS INC.

BENEFITS AND FEATURES

- Versatile digital design
- Large, easy-to-use adjustments and three-digit seven-segment LED display
- Wide range of supply voltage
- Electronic limiting circuit / short circuit proof
- Load can be connected & disconnected live
- Protected against wrong connection
- Energy-efficient PWM circuit, no heat sink is required
- Current sensing maintains output regardless of changes in supply voltage and coil resistance
- Simple control with analog input, the reference voltage is locally supplied
- Can be used either for one dual solenoid valve or two independent single valves
- Plastic box with clear lid
- Three PG7 liquid-tight cable glands for power, signals and coils



SPECIFICATIONS

- Operating voltage: 9 - 35VDC
- Maximum output current: 3A
- Ramp time: 0.0 to 99.5s
- Linearity: 0.5%
- PWM / Dither frequency: 50-500Hz
- Operating temperature: -40° to +75° Celsius
- Input signals: user selectable 0-5V, 0-10V, 0-20mA or 4-20mA
- Protection grade: NEMA 4X
- Size: 4.75" long x 2.25" deep x 3.15" wide (4.15" with cable glands)
- Weight: 0.6lbs

This product fulfills
the essential
requirements of
the EMC Directive
2004/108/EC:
EN61000-6-1:2005,
EN61000-6-3:2006

PVD3D2N

Proportional Valve Driver

Two PWM solenoid outputs, in sealed plastic enclosure

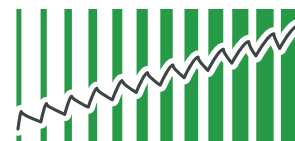
**PWM**

CONTROLS INC.

SETTINGS AND RANGE

| | |
|-------------|---|
| AH I | A high, output current corresponding to the highest input, 0.00 to 3.00 A |
| AJ9 | A jog, output current manual override, 0.00 to 3.00 A |
| ALO | A low, output current corresponding to the lowest input, 0.00 to 3.00 A |
| AUP | A ramp up, time required for the output to increase from ALO to AH I, 0.00 to 99.5 s |
| Adn | A ramp down, time required for the output to decrease from AH I to ALO, 0.00 to 99.5 s |
| Adb | A deadband, output is disabled when signal is less than this setting, in % |
| Ain | Single mode A input signal, 005 (0-5V), 0 1 0 (0-10V), 020 (0-20mA) or 420 (4-20mA) |
| bH I | B high, output current corresponding to the highest input, 0.00 to 3.00 A |
| BJ9 | B jog, output current manual override, 0.00 to 3.00 A |
| bLO | B low, output current corresponding to the lowest input, 0.00 to 3.00 A |
| bUP | B ramp up, time required for the output to increase from bLO to bH I, 00.0 to 99.5 s |
| bdn | B ramp down, time req'd for the output to decrease from bH I to bLO, 00.0 to 99.5 s |
| bdb | B deadband, output is disabled when signal is less than this setting, in % |
| bin | Single mode B input signal: 005 (0-5V), 0 1 0 (0-10V), 020 (0-20mA) or 420 (4-20mA) |
| db | Dual mode deadband, output is disabled when signal is less than this setting, in % |
| dF | Dither frequency, 050 to 500 Hz |
| in | Dual mode input signal selection: 005 (0-5V), 0 1 0 (0-10V), 020 (0-20mA) or 420 (4-20mA) |
| di | Display orientation, normal or up-side-down |
| SA | Save settings |

SETUP PROCEDURE

At power up, you may rotate the left side control # to read the command input signal in V or mA, corresponding to the input range pre-selected or the actual solenoid output current directly in Amps: **Ain** (A input), **Aot** (A output), **bin** (B input) or **bot** (B output). To enter set-up mode, rotate right side control *; the display will show the settings sequentially: **AH I**, **AJ9**, **ALO**, **AUP**, **Adn**, **Adb**, **Ain**, **bH I**, **BJ9**, **bLO**, **bUP**, **bdn**, **bdb**, **bin**, **db**, **dF**, **in**, **di** and **SA**. When you reach the setting that you want to modify, rotate # up or down to the desired value. To modify another setting, rotate * and repeat. The Driver is fully functional during the set-up procedure with any adjustments effective immediately (except the input range selection that becomes effective only after saving). In order to write the new settings in the memory and return to normal mode of operation, rotate * until the display shows **SA** and then rotate # one full turn. If you do not want to keep the new settings, simply power down without saving.

WE RESERVE THE RIGHT TO DISCONTINUE MODELS OR CHANGE SPECIFICATIONS WITHOUT NOTICE OR INCURRING OBLIGATION

PVD3D2N

Proportional Valve Driver
Two PWM solenoid outputs, in sealed plastic enclosure



PWM

CONTROLS INC.

DUAL MODE WIRING DIAGRAMS FOR ONE DUAL SOLENOID VALVE:

With signal from Analogue Card/PLC:

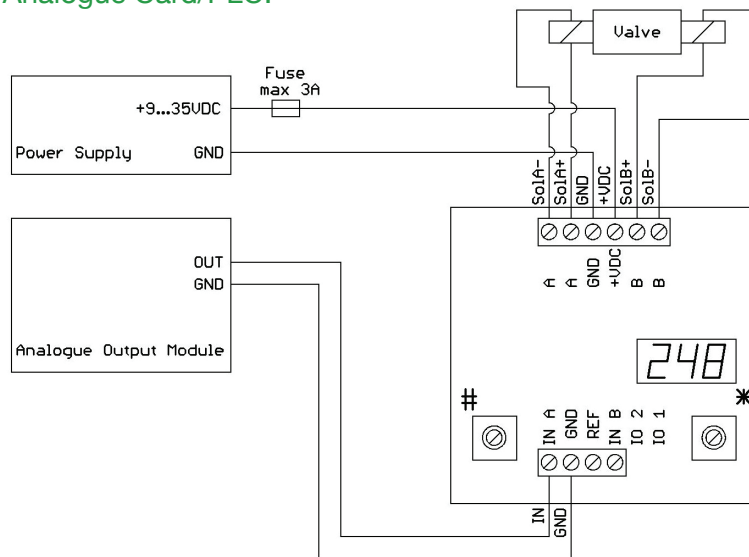

With signal from potentiometer/joystick:

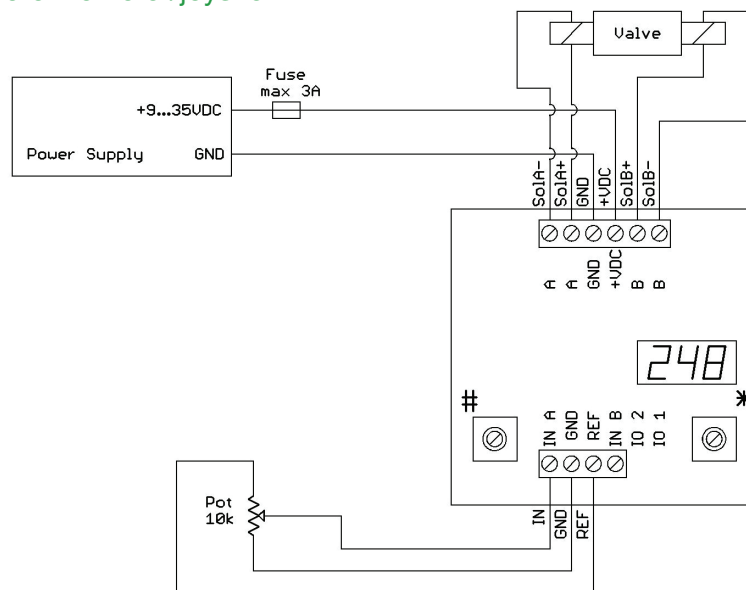

PVD3D2N

Proportional Valve Driver
Two PWM solenoid outputs, in sealed plastic enclosure



SINGLE MODE WIRING DIAGRAMS FOR TWO INDEPENDENT SOLENOIDS:

With signal from Analogue Card/PLC:

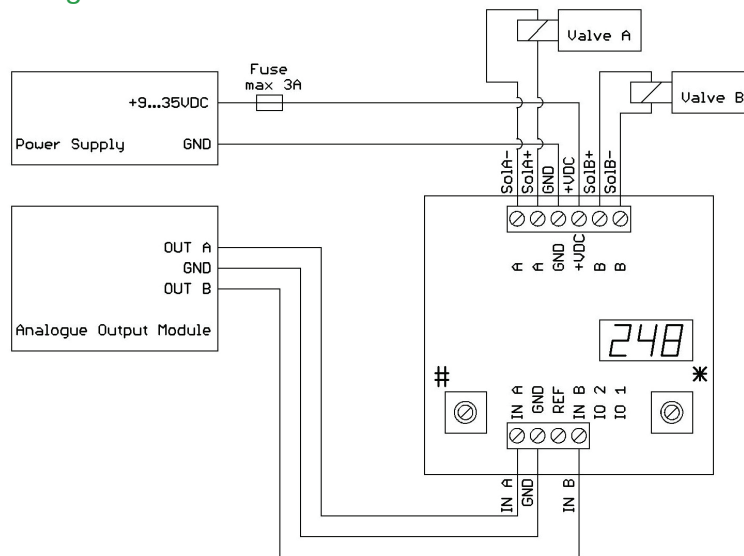

With signal from potentiometer/joystick:

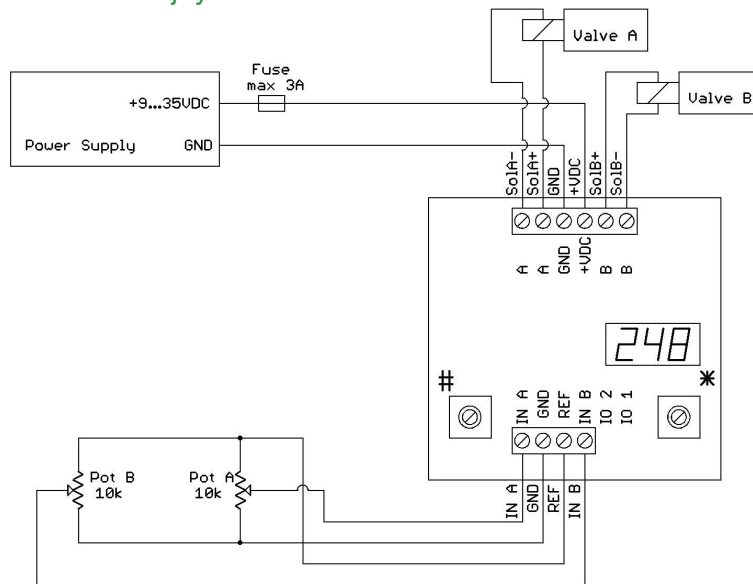

PVD3D2N

Proportional Valve Driver
Two PWM solenoid outputs, in sealed plastic enclosure



PWM

CONTROLS INC.

FUNCTIONAL DIAGRAMS:

Dual mode: one dual solenoid valve:

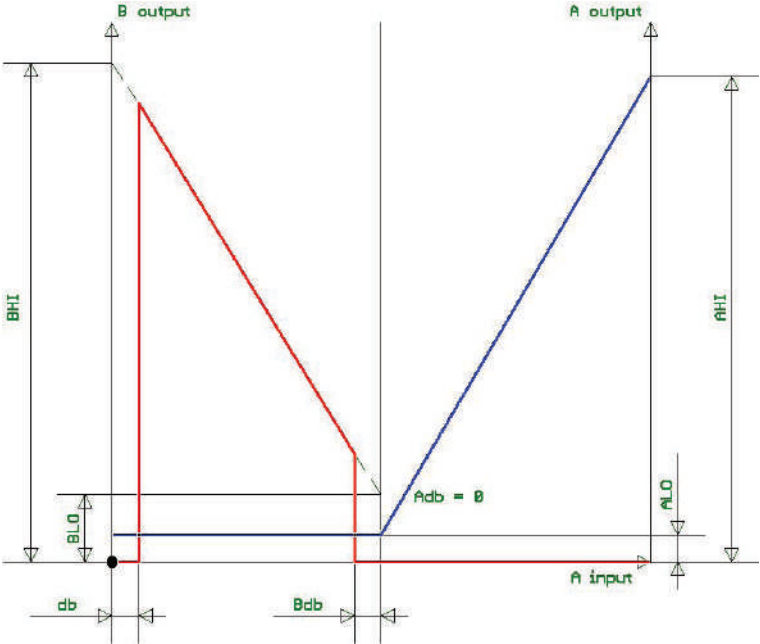

Single mode: two independent solenoids:

