



PVD3S2E

Proportional Valve Driver, two PWM solenoid outputs, epoxy potted

BENEFITS AND FEATURES:

- Versatile digital design
- Large, easy-to-use adjustments and three-digit seven-segment LED display
- Wide range of supply voltage
- Electronic limiting circuit / short circuit proof
- Load can be connected & disconnected live
- Protected against wrong connection
- Energy-efficient PWM circuit, no heat sink is required
- Current sensing maintains output regardless of changes in supply voltage and coil resistance
- Simple control with two digital inputs per channel
- Can be used either for one dual solenoid valve or two independent single valves
- Environmentally sealed



SPECIFICATIONS:

- Operating voltage: 9 - 35VDC
- Maximum output current: 3A
- Ramp time: 0.0 to 99.5s
- Linearity: 0.5%
- PWM / Dither frequency: 50-500Hz
- Operating temperature: -40° to +75° Celsius
- Input signals: four digital (on/off)
- Size: 3.00" x 0.875" x 3.25" (4.00" with flanges)

This product fulfills the essential requirements of
the EMC Directive 2004/108/EC: EN61000-6-1:2005, EN61000-6-3:2006



PVD3S2E

Proportional Valve Driver, two PWM solenoid outputs, epoxy potted

SETTINGS AND RANGE:

- AJ9** A jog, used to simulate signal, 0.00 to 3.00 A
- AP 1** Set point A1, 0.00 to 3.00 A
- AP2** Set point A2, 0.00 to 3.00 A
- AP3** Set point A3, 0.00 to 3.00 A
- AP4** Set point A4, 0.00 to 3.00 A
- AUP** A ramp up, time required for the output to increase 1A, 00.0 to 99.5 s
- Adn** A ramp down, time required for the output to decrease 1A, 00.0 to 99.5 s
- bJ9** B jog, used to simulate signal, 0.00 to 3.00 A
- bP 1** Set point B1, 0.00 to 3.00 A
- bP2** Set point B2, 0.00 to 3.00 A
- bP3** Set point B3, 0.00 to 3.00 A
- bP4** Set point B4, 0.00 to 3.00 A
- bUP** B ramp up, time required for the output to increase 1A, 00.0 to 99.5 s
- bdn** B ramp down, time required for the output to decrease 1A, 00.0 to 99.5 s
- dF** Dither frequency, 050 to 500 Hz
- di** Display orientation, normal or up-side-down
- SA** Save settings

SET-UP PROCEDURE:

At power up, you may rotate the left side control **#** to read the target set point or the actual solenoid output current directly in Amps: **Ain** (A target), **Aot** (A actual), **bin** (B target) or **bot** (B actual). To enter set-up mode, rotate right side control *****; the display will show the settings sequentially: **AJ9**, **AP 1**, **AP2**, **AP3**, **AP4**, **AUP**, **Adn**, **bJ9**, **bP 1**, **bP2**, **bP3**, **bP4**, **bUP**, **bdn**, **dF**, **di** and **SA**.

When you reach the setting that you want to modify, rotate **#** up or down to the desired value. To modify another setting, rotate ***** and repeat. The Driver is fully functional during the set-up procedure with any adjustments effective immediately (except the input range selection that becomes effective only after saving). In order to write the new settings in the memory and return to normal mode of operation, rotate ***** until the display shows **SA** and then rotate **#** one full turn. If you do not want to keep the new settings, simply power down without saving.

WE RESERVE THE RIGHT TO DISCONTINUE MODELS OR CHANGE SPECIFICATIONS
WITHOUT NOTICE OR INCURRING OBLIGATION

PVD3S2E



PVD3S2E

Proportional Valve Driver, two PWM solenoid outputs, epoxy potted

WIRING DIAGRAMS:

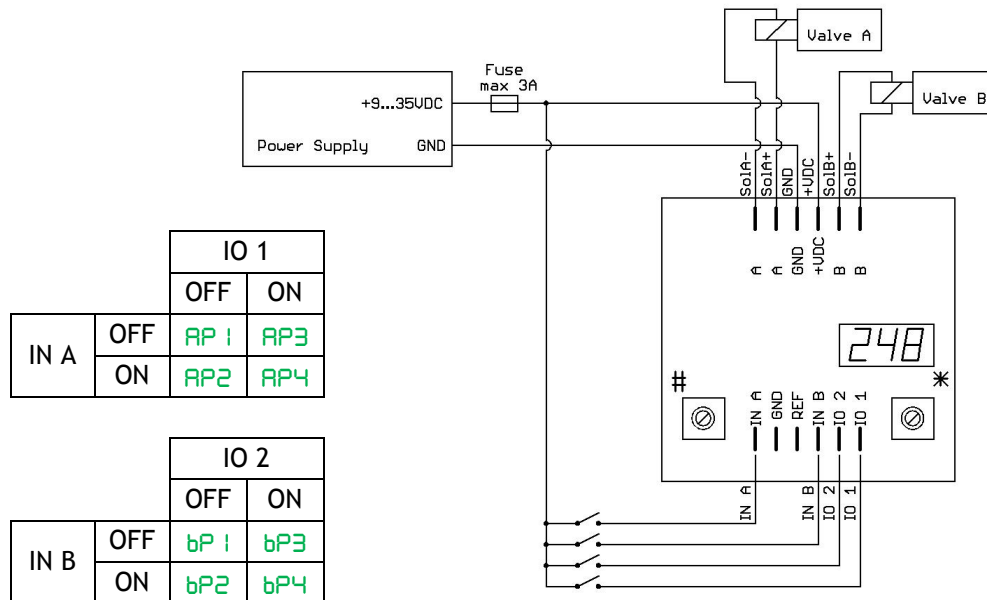
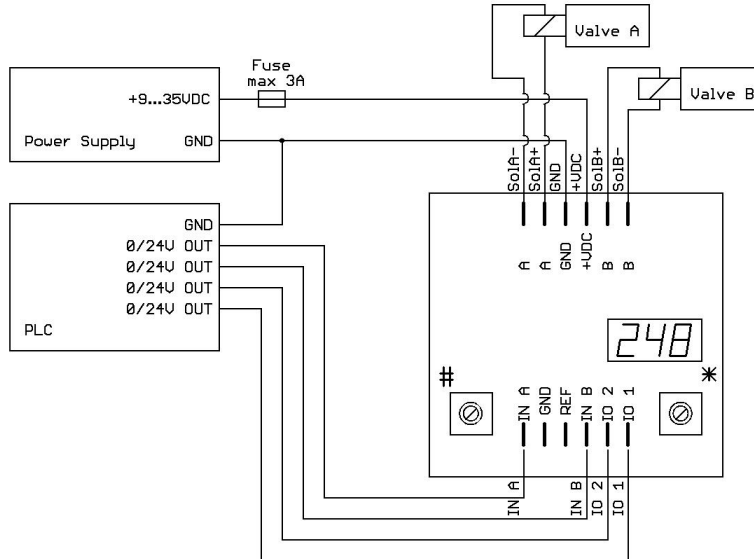

PVD3S2E