



PVD3X2E

Proportional Valve Driver

Two PWM solenoid outputs, epoxy potted

BENEFITS AND FEATURES

- Versatile digital design
- Large, easy-to-use adjustments and three-digit seven-segment LED display
- Wide range of supply voltage
- Electronic limiting circuit / short circuit proof
- Load can be connected & disconnected live
- Protected against wrong connection
- Energy-efficient PWM circuit, no heat sink is required
- Current sensing maintains output regardless of changes in supply voltage and coil resistance
- Simple control with analog input
- Can be used for one dual solenoid proportional valve
- Environmentally sealed



SPECIFICATIONS

- Operating voltage: 9 - 35VDC
- Maximum output current: 3A
- Ramp time: 0.0 to 99.5s
- Linearity: 0.5%
- PWM / Dither frequency: 50-500Hz
- Operating temperature: -40° to +75° Celsius
- Input signal: differential -10V to +10V
- Size: 3.00" x 0.875" x 3.25" (4.00" with flanges)
- Weight: 0.3lbs
- Protection grade: IP67

This product fulfills
 the essential
 requirements of
 the EMC Directive
 2004/108/EC:
 EN61000-6-1:2005,
 EN61000-6-3:2006

PVD3X2E

Proportional Valve Driver
Two PWM solenoid outputs, epoxy potted



SETTINGS AND RANGE

AH I	A high, output current corresponding to +10V input, 0.00 to 3.00 A
AJ9	A jog, output current manual override, 0.00 to 3.00 A
ALO	A low, output current corresponding to 0V input, 0.00 to 3.00 A
AUP	A ramp up, time required for the output to increase from ALO to AH I, 0.00 to 99.5 s
Adn	A ramp down, time required for the output to decrease from AH I to ALO, 0.00 to 99.5 s
Adb	A deadband, output is disabled when signal is less than this setting, in %
bH I	B high, output current corresponding to -10V input, 0.00 to 3.00 A
BJ9	B jog, output current manual override, 0.00 to 3.00 A
bLO	B low, output current corresponding to 0V input, 0.00 to 3.00 A
bUP	B ramp up, time required for the output to increase from bLO to bH I, 00.0 to 99.5 s
bdn	B ramp down, time req'd for the output to decrease from bH I to bLO, 00.0 to 99.5 s
bdb	B deadband, output is disabled when signal is less than this setting, in %
dF	Dither frequency, 050 to 500 Hz
di	Display orientation, normal or up-side-down
SA	Save settings

SETUP PROCEDURE

At power up, you may rotate the left side control # to read the command input signal in V or the actual solenoid output current directly in Amps: **in** (input) or **ot** (output). The red LED signals negative input / solenoid B active, the green LED signals positive input / solenoid A active. To enter setup mode, rotate right side control * ; the display will show the settings sequentially: **AH I**, **AJ9**, **ALO**, **AUP**, **Adn**, **Adb**, **bH I**, **BJ9**, **bLO**, **bUP**, **bdn**, **bdb**, **dF**, **di** and **SA**. When you reach the setting that you want to modify, rotate # up or down to the desired value. To modify another setting, rotate * and repeat. The Driver is fully functional during the set-up procedure with any adjustments effective immediately (except the input range selection that becomes effective only after saving). In order to write the new settings in the memory and return to normal mode of operation, rotate * until the display shows **SA** and then rotate # one full turn. If you do not want to keep the new settings, simply power down without saving.

WE RESERVE THE RIGHT TO DISCONTINUE MODELS OR CHANGE SPECIFICATIONS WITHOUT NOTICE OR INCURRING OBLIGATION

PVD3X2E

Proportional Valve Driver
Two PWM solenoid outputs, epoxy potted



WIRING DIAGRAM

With signal from Analogue Card/PLC:

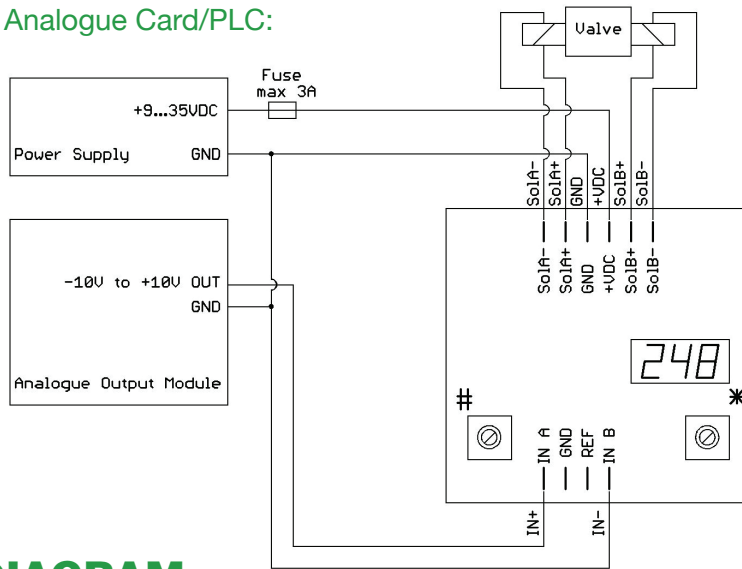

FUNCTIONAL DIAGRAM

